

AWK-4252A Series

Outdoor industrial IEEE 802.11a/b/g/n/ac wireless AP/bridge/client



Features and Benefits

- IEEE 802.11a/b/g/n/ac Wave 2 AP/bridge/client
- Concurrent dual-band Wi-Fi with aggregated data rates up to 1.267 Gbps
- Latest WPA3 encryption for enhanced wireless network security
- Universal (UN) models with configurable country or region code for more flexible deployment
- Easy network setup with Network Address Translation (NAT)
- Millisecond-level Client-based Turbo Roaming¹
- Built-in 2.4 GHz and 5 GHz band pass filter for more reliable wireless connections
- IP68-rated weatherproof housing designed for outdoor applications and -40 to 75°C wide operating temperature range
- Integrated antenna isolation
- Developed according to the IEC 62443-4-1 and compliant with the IEC 62443-4-2 industrial cybersecurity standards

Certifications



Introduction

The AWK-4252A Series 3-in-1 industrial wireless AP/bridge/client is designed to meet the growing need for faster data transmission speeds through IEEE 802.11ac technology for aggregated data rates of up to 1.267 Gbps. The AWK-4252A is compliant with industrial standards and approvals covering operating temperature, power input voltage, surge, ESD, and vibration. The two redundant DC power inputs increase the reliability of the power supply, and the AWK-4252A can be powered via PoE to facilitate flexible deployment. The AWK-4252A can operate concurrently on both the 2.4 and 5 GHz bands and is backwards-compatible with existing 802.11a/b/g/n deployments to future-proof your wireless investments.

The AWK-4252A Series is compliant with the IEC 62443-4-2 and IEC 62443-4-1 Industrial Cybersecurity certifications, which cover both product security and secure development life-cycle requirements, helping our customers meet the compliance requirements of secure industrial network design.

Advanced 802.11ac Industrial Wireless Solution

- 802.11a/b/g/n/ac compliant AP/bridge/client for flexible deployment
- DFS channel support allows a wider range of 5 GHz channel selection to avoid interference from existing wireless infrastructure

Advanced Wireless Technology

- Seamless roaming with client-based Turbo Roaming¹ for < 150 ms roaming recovery time between APs (Client Mode)

Industrial Ruggedness

- -40 to 75°C wide operating temperature for smooth wireless communication in harsh environments
- Enhanced antenna port isolation protection designed to withstand up to 30 kV ESD and 6 kV surge protection

1. The Turbo Roaming recovery time indicated herein is an average of test results documented, in optimized conditions, across APs configured with interference-free 20-MHz RF channels, WPA2-PSK security, and default Turbo Roaming parameters. The clients are configured with 3-channel roaming at 100 Kbps traffic load. Other conditions may also impact roaming performance. For more information about Turbo Roaming parameter settings, refer to the product manual.

Specifications

WLAN Interface

WLAN Standards	2.4 GHz: 802.11b/g/n with 256 QAM support 5 GHz: 802.11a/n/ac Wave 2 with 256 QAM support
Frequency Band for US (20 MHz operating channels)	AWK-4252A US Models Only: 2.412 to 2.462 GHz (11 channels) 5.180 to 5.240 GHz (4 channels) 5.260 to 5.320 GHz (4 channels) ² 5.500 to 5.700 GHz (11 channels) ² 5.745 to 5.825 GHz (5 channels)
Frequency Band for UN (20 MHz operating channels)	AWK-4252A UN Models Only: 2.412 to 2.484 GHz (14 channels) 5.180 to 5.240 GHz (4 channels) 5.260 to 5.320 GHz (4 channels) ² 5.500 to 5.700 GHz (11 channels) ² 5.745 to 5.825 GHz (5 channels) Available channels change depending on the selected country or region code.
Wireless Security	WEP encryption (64-bit and 128-bit) WPA/WPA2/WPA3-Enterprise (IEEE 802.1X/RADIUS, TKIP, AES) WPA/WPA2/WPA3-Personal
Transmission Rate	2.4 GHz: 802.11b: 1 to 11 Mbps 802.11g: 6 to 54 Mbps 802.11n: 6.5 to 400 Mbps 5 GHz: 802.11a: 6 to 54 Mbps 802.11n: 6.5 to 300 Mbps 802.11ac: 6.5 to 867 Mbps
Transmitter Power for 802.11a (Dual Chain)	24±1.5 dBm @ 6 Mbps 22±1.5 dBm @ 54 Mbps
Transmitter Power for 802.11n (5 GHz, Dual Chain)	24±1.5 dBm @ MCS0 20 MHz 21±1.5 dBm @ MCS7 20 MHz 23±1.5 dBm @ MCS0 40 MHz 21±1.5 dBm @ MCS7 40 MHz
Transmitter Power for 802.11ac (Dual Chain)	23.5±1.5 dBm @ MCS0 20 MHz 20.5±1.5 dBm @ MCS8 20 MHz 23.5±1.5 dBm @ MCS0 40 MHz 20±1.5 dBm @ MCS9 40 MHz 22.5±1.5 dBm @ MCS0 80 MHz 20±1.5 dBm @ MCS9 80 MHz
Transmitter Power for 802.11b (Dual Chain)	27.5±1.5 dBm @ 1 Mbps 28±1.5 dBm @ 11 Mbps
Transmitter Power for 802.11g (Dual Chain)	28±1.5 dBm @ 6 Mbps 25±1.5 dBm @ 54 Mbps
Transmitter Power for 802.11n (2.4 GHz, Dual Chain)	26±1.5 dBm @ MCS0 20 MHz 24±1.5 dBm @ MCS7 20 MHz 26±1.5 dBm @ MCS0 40 MHz 24.5±1.5 dBm @ MCS7 40 MHz
Receiver Sensitivity for 802.11a (measured at 5.680 GHz)	Typ. -88 @ 6 Mbps Typ. -71 @ 54 Mbps
Receiver Sensitivity for 802.11n (5 GHz; measured at 5.680 GHz)	Typ. -87 dBm @ MCS0 20 MHz Typ. -68 dBm @ MCS7 20 MHz Typ. -83 dBm @ MCS0 40 MHz Typ. -66 dBm @ MCS7 40 MHz

2. DFS (Dynamic Frequency Selection) channel support: In AP mode, when a radar signal is detected, the device will automatically switch to another channel. However, according to regulations, after switching channels, a 60-second availability check period is required before starting the service.

Receiver Sensitivity for 802.11ac	Typ. -87 dBm @ MCS0 20 MHz Typ. -64 dBm @ MCS8 20 MHz Typ. -84 dBm @ MCS0 40 MHz Typ. -59 dBm @ MCS9 40 MHz Typ. -81 dBm @ MCS0 80 MHz Typ. -56 dBm @ MCS9 80 MHz
Receiver Sensitivity for 802.11b (measured at 2.437 GHz)	Typ. -93 dBm @ 1 Mbps Typ. -86 dBm @ 11 Mbps Note: Concurrent USB read/write activity on the device may generate interference and may mildly affect receiver sensitivity performance. It is recommended to avoid USB activity on the device in mission-critical applications.
Receiver Sensitivity for 802.11g (measured at 2.437 GHz)	Typ. -88 dBm @ 6 Mbps Typ. -71 dBm @ 54 Mbps Note: Concurrent USB read/write activity on the device may generate interference and may mildly affect receiver sensitivity performance. It is recommended to avoid USB activity on the device in mission-critical applications.
Receiver Sensitivity for 802.11n (2.4 GHz; measured at 2.437 GHz)	Typ. -87 dBm @ MCS0 20 MHz Typ. -68 dBm @ MCS7 20 MHz Typ. -84 dBm @ MCS0 40 MHz Typ. -66 dBm @ MCS7 40 MHz Note: Concurrent USB read/write activity on the device may generate interference and may mildly affect receiver sensitivity performance. It is recommended to avoid USB activity on the device in mission-critical applications.
WLAN Operation Mode	Access point Client Client-Router Master Slave Sniffer
Antenna	External, 3/6 dBi Omni-directional
Antenna Connectors	2 x N-type female
Ethernet Interface	
Standards	IEEE 802.3 for 10BaseT IEEE 802.3u for 100BaseT(X) IEEE 802.3ab for 1000BaseT(X) IEEE 802.3af for PoE IEEE 802.3at for PoE IEEE 802.1Q for VLAN Tagging IEEE 802.1X for authentication
10/100/1000BaseT(X) Ports (RJ45 connector)	1
PoE Ports (10/100/1000BaseT(X), RJ45 connector)	1
Ethernet Software Features	
Management	DHCP Server DHCP Client DNS HTTP IPv4 LLDP SMTP SNMPv1/v2c/v3 Syslog TCP/IP Telnet UDP VLAN MXconfig
Routing	Port forwarding Static Route

	NAT
Security	HTTPS/SSL RADIUS SSH Certificate Management
Time Management	SNTP Client
Firewall	
Filter	ICMP MAC address IP protocol Port-based Wi-Fi ACL Client Isolation
Serial Interface	
Console Port	RS-232 8-pin RJ45
USB Interface	
Storage Port	USB Type A
LED Interface	
LED Indicators	PWR, LAN1, LAN2, 2.4G, 5G, SYS
Input/Output Interface	
Digital Inputs	2 Max. input current: 8 mA +13 to +30 V for state 1 +3 to -30 V for state 0
Alarm Contact Channels	Relay output with current carrying capacity of 1 A @ 24 VDC
Buttons	Reset button
Physical Characteristics	
Housing	Metal
Dimensions	66.5 x 157.6 x 244 mm (2.56 x 6.20 x 9.61 in)
IP Rating	IP68
Weight	2024 g (4.7 lb)
Installation	Wall mounting DIN-rail mounting (with optional kit) Pole mounting (with optional kit)
Power Parameters	
Input Current	12-48 VDC, 2.2-0.55 A
Input Voltage	12 to 48 VDC Redundant dual inputs 48 VDC Power-over-Ethernet
Power Connector	M12 A-coded 5-pin male connector
Power Consumption	28.4 W (max.)

Environmental Limits

Operating Temperature	Wide Temp. Models: -40 to 75°C (-40 to 167°F)
Storage Temperature (package included)	-40 to 85°C (-40 to 185°F)
Ambient Relative Humidity	5 to 95% (non-condensing)

Standards and Certifications

EMC	EN 61000-6-2/-6-4 EN 55032/35
EMI	CISPR 32, FCC Part 15B Class A
EMS	IEC 61000-4-2 ESD: Contact: 8 kV; Air: 15 kV IEC 61000-4-3 RS: 80 MHz to 1 GHz: 10 V/m IEC 61000-4-4 EFT: Power: 2 kV; Signal: 1 kV IEC 61000-4-5 Surge: Power: 2 kV; Signal: 1 kV IEC 61000-4-6 CS: 10 V/m IEC 61000-4-8 PFMF: 30 A/m
Safety	IEC 60950-1 IEC 62368-1 UL 62368-1
Vibration	IEC 60068-2-6
Radio	EN 300 328, EN 301 489-1/17, EN 301 893, ANATEL, FCC, MIC, NCC, RCM, SRRC, WPC, KC, NBTC, IC
Industrial Cybersecurity	IEC 62443-4-1 IEC 62443-4-2

MTBF

Time	746,471 hrs
Standards	Telcordia SR332

Warranty

Warranty Period	5 years
Details	See www.moxa.com/warranty

Package Contents

Device	1 x AWK-4252A Series wireless AP/bridge/client
Installation Kit	2 x cap, plastic, for N-type connector 4 x cap, metal, for Console/USB/LAN1/LAN2 1 x cap, metal, for DI/DO port 1 x wall-mounting kit
Antenna	2 x 2.4/5 GHz antenna
Documentation	1 x quick installation guide 1 x warranty card

Dimensions

Unit: mm

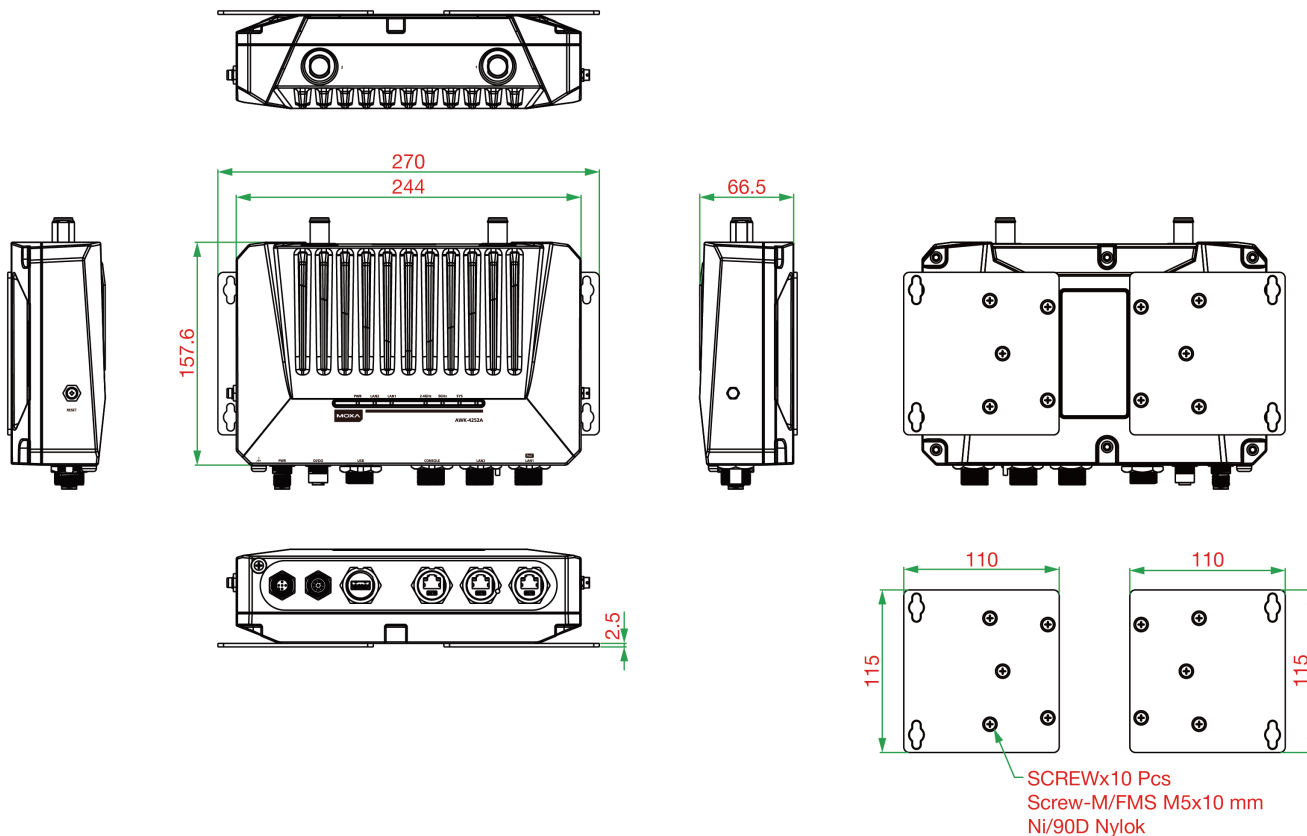

Ordering Information

Model Name	Band	Standards	Operating Temp.
AWK-4252A-UN-T	UN	802.11a/b/g/n/ac Wave 2	-40 to 75°C
AWK-4252A-US-T	US	802.11a/b/g/n/ac Wave 2	-40 to 75°C

Accessories (sold separately)

Antennas

ANT-WSB-PNF-12-02	12 dBi at 2.4 GHz, N-type (female), single-band directional antenna
ANT-WSB5-PNF-16	16 dBi at 5 GHz, N-type (female), single-band directional antenna
ANT-WDB-ONM-0707	07 dBi at 2.4 GHz and 07 dBi at 5 GHz, N-type (male), dual-band omnidirectional antenna
ANT-WDB-PNF-1011	10 dBi at 2.4 GHz and 11 dBi at 5 GHz, N-type (female), dual-band directional antenna
ANT-WDB-ONF-0709	7 dBi at 2.4 GHz or 9 dBi at 5 GHz, N-type (female), dual-band, omnidirectional antenna
ANT-WDB-ANM-0306	3 dBi at 2.4 GHz or 6 dBi at 5 GHz, N-type (male), omnidirectional antenna
MAT-WDB-PA-NF-2-0708	2.4/5 GHz, panel antenna, 7/8 dBi, MIMO 2x2, N-type (female)
ANT-WDB-ANM-0502	5 dBi at 2.4 GHz or 2 dBi at 5 GHz, N-type (male), omnidirectional antenna

Wireless Antenna Cables

A-CRF-NMNM-LL4-900	N-type (male) to N-type (male) LMR-400 Lite cable, 9 m
A-CRF-NMNM-LL4-600	N-type (male) to N-type (male) LMR-400 Lite cable, 6 m
A-CRF-NMNM-LL4-300	N-type (male) to N-type (male) LMR-400 Lite cable, 3 m

Surge Arrestors

A-SA-NMNF-02	0 to 6 GHz, N-type (male) to N-type (female) surge arrester
--------------	---

A-SA-NFNF-02	0 to 6 GHz, N-type (female) to N-type (female) surge arrester
--------------	---

Wireless Terminating Resistors

A-TRM-50-NM	50-ohm termination resistor with N-type male connector
-------------	--

Mounting Kits

PK-DC2DOF	Pole mounting kit
-----------	-------------------

PK-DC2DOF-02	PK-DC2DOF-02
--------------	--------------

Wireless Connector Caps

A-CAP-M12M-M	Metal cap for M12 male connector
--------------	----------------------------------

© Moxa Inc. All rights reserved. Updated May 10, 2023.

This document and any portion thereof may not be reproduced or used in any manner whatsoever without the express written permission of Moxa Inc. Product specifications subject to change without notice. Visit our website for the most up-to-date product information.